

DX/HL SERIES

TUBE HEATER

OPERATION, INSTALLATION, MAINTENANCE
AND PARTS MANUAL

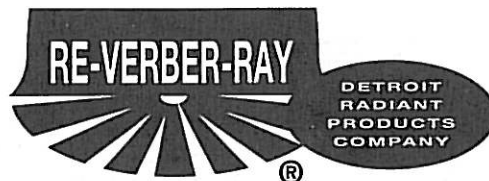

FOR YOUR SAFETY!

IF YOU SMELL GAS:

1. Open windows.
2. Do not touch electrical switches.
3. Extinguish any open flame.
4. Immediately call your gas supplier.

FOREWORD



WARNING

THIS HEATER MUST BE INSTALLED AND SERVICED BY TRAINED GAS INSTALLATION AND SERVICE PERSONNEL ONLY. READ AND UNDERSTAND THESE INSTRUCTIONS THOROUGHLY BEFORE ATTEMPTING TO INSTALL, OPERATE OR SERVICE THE DETROIT RADIANT PRODUCTS COMPANY HEATER. FAILURE TO COMPLY WITH THESE WARNINGS AND INSTRUCTIONS, AND THOSE ON THE HEATER, COULD RESULT IN PERSONAL INJURY, DEATH, FIRE, ASPHYXIATION, AND/OR PROPERTY DAMAGE. RETAIN THESE INSTRUCTIONS FOR FUTURE REFERENCE.

Approval Standards and Certifications

Detroit Radiant Products units comply with or are certified by the following organizations or standards:

- American National Standards (ANSI Z83.6)
- Occupational Safety & Health Act (OSHA)
- American Gas Association (AGA)

IMPORTANT

Any alteration of this system or of the factory-authorized components specified either in this manual or by Detroit Radiant Products Company voids all certifications and warranties.

Detroit Radiant Products Company

21400 Hoover Road • Warren MI 48089 • (810) 756-0950 • Fax: (810) 756-2626

TABLE OF CONTENTS

	<u>Page</u>
1 SAFETY INFORMATION	2
2 INSTALLATION	4
2.1 Design Criteria	4
2.2 Prechecks	6
2.3 Heater Mounting	8
2.4 Reflector Assembly	10
2.5 Optional "L" or "U" Configuration	11
2.6 Flue Venting	12
2.7 Installation for Unvented Operation (Optional)	14
2.8 Combustion Air Requirements	15
2.9 Gas Supply	16
2.10 Electrical Requirements	18
2.11 Lighting Instructions	19
2.12 Shutdown Instructions	19
3 THEORY OF OPERATION	20
3.1 DX Models	20
3.2 HL Models	21
4 MAINTENANCE	22
4.1 Troubleshooting Chart	23
5 PARTS LIST	24
5.1 Basic Parts List	24
5.2 Optional Parts	24

1 SAFETY INFORMATION



WARNING

NOT FOR RESIDENTIAL USE!

Do not use in the home, sleeping quarters, attached garages, etc.



WARNING

This is not an explosion-proof heater. Where there is the possibility of exposure to flammable vapors, consult the local fire marshal, the fire insurance carrier or other authorities for approval of the proposed installation.

This infrared heater is designed for use in industrial and commercial buildings such as warehouses, manufacturing plants, aircraft hangars, service garages, etc.

Detroit Radiant Products Company cannot anticipate every use which may be made of their heaters. Check with your local fire safety authority if you have questions about local regulations.

CAUTION

The following information **must** be reviewed before installing this heater:

- Check the AGA rating label on the heater to verify the proper gas to be used. Check the other labels on the heater to verify proper mounting and clearances to combustibles.
- The installation of this heater must conform with local building codes or, in the absence of local codes, with the latest edition of the National Fuel Gas Code, ANSI Z223.1 (NFPA 54).
- The installation of this heater in public garages must conform with the latest edition of the Standard for Parking Structures, ANSI/NFPA 88A, or the Standard for Repair Garages, ANSI/NFPA 88B, and must be at least 8 ft above the floor.
- The installation of this heater in aircraft hangars must conform with the latest edition of the Standard for Aircraft Hangars, ANSI/NFPA 409. The heater must be installed at least 10 ft above the upper wing surfaces and engine enclosures of the highest aircraft which might be stored in the hangar. In areas adjoining the aircraft storage area, the heaters must be installed at least 8 ft above the floor. The heaters must be located in areas where they will not be subject to damage by aircraft, cranes, movable scaffolding or other objects.
- The heater, when installed, must be electrically grounded in accordance with the latest edition of the National Electrical Code, ANSI/NFPA 70.
- Under no circumstance is either the gas supply line or the electrical supply line to the heater to provide any assistance in the suspension of the heater.
- The weight of the heater must be entirely suspended from a permanent part of the building structure having adequate load characteristics.
- Neither the gas supply line, electrical supply line nor sprinkler heads shall be located within the minimum clearances to combustibles as shown in the Clearances-to-Combustibles Chart on page 3.
- Signs should be posted in storage areas to specify maximum stacking height allowed in order to maintain clearance to combustibles.



WARNING

Failure to comply with the stated clearances to combustibles could result in personal injury, death and/or property damage.



WARNING

This heater should be installed so that the minimum clearances to vehicles, as marked on the heater, will be maintained. If vehicle lifts are present, ensure that these clearances will be maintained from the highest raised vehicle.

For the safe installation of this heater, the following table contains clearances that must be maintained:

CLEARANCES TO COMBUSTIBLES (IN.)					
MODEL NO.	MOUNTING	SIDE		TOP	BELOW
	ANGLE	FRONT	BEHIND		
DX (20,30,40) -50(N,P) W/ 1 side shield W/ 2 side shields 20 ft from burner	0°	9	9	6	47
	45°	39	8	10	47
	0°	29	8	6	47
	0°	9	9	6	47
DX (20,30,40) -60(N,P) W/ 1 side shield W/ 2 side shields 20 ft from burner	0°	9	9	6	47
	45°	39	8	10	47
	0°	29	8	6	47
	0°	9	9	6	47
DX (20,30,40) -75(N,P) HL (20,30,40) -75(N,P) W/ 1 side shield W/ 2 side shields 20 ft from burner	0°	9	9	6	60
	45°	39	8	10	60
	0°	29	8	6	60
	0°	9	9	6	60
DX (30,40,50) -100(N,P) HL (30,40,50) -100(N,P) W/ 1 side shield W/ 2 side shields 20 ft from burner	0°	14	14	6	66
	45°	39	8	10	66
	0°	29	8	6	66
	0°	16	16	6	66
DX (40,50,60) -125(N,P) W/ 1 side shield W/ 2 side shields 20 ft from burner	0°	20	20	6	76
	45°	58	8	10	76
	0°	42	8	6	76
	0°	20	20	6	76
DX (40,50,60) -150(N,P) HL (40,50,60) -150(N,P) W/ 1 side shield W/ 2 side shields 20 ft from burner	0°	24	24	6	81
	45°	58	8	10	81
	0°	42	8	6	81
	0°	23	23	6	81
DX (50,60,70) -175(N,P) W/ 1 side shield W/ 2 side shields 20 ft from burner	0°	34	34	6	92
	45°	63	8	10	92
	0°	50	8	6	92
	0°	30	30	6	92
DX (50,60,70.80) -200(N,P) HL (50,60,70) -200(N,P) W/ 1 side shield W/ 2 side shields 20 ft from burner	0°	41	41	6	94
	45°	63	8	10	94
	0°	54	8	6	94
	0°	30	30	6	94
	0°	11	11	6	44

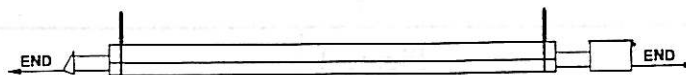
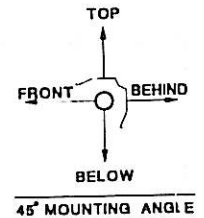
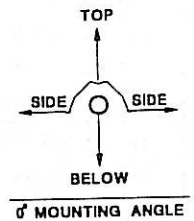
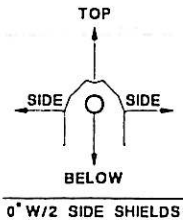
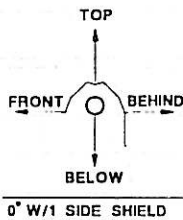

THE MINIMUM END CLEARANCE FOR ALL MODELS IS 12 INCHES.

2 INSTALLATION

2.1 Design Criteria

Perimeter mounting of these infrared heaters provides for the most efficient installation. In Figure 1-1, the heaters are mounted at the perimeter of the space to be heated. Refer to the DX/HL Heater

Installation Chart for the recommended distances on the models being installed. Buildings that require the rows of heaters to be farther apart than the recommended distance in the chart may need additional heaters placed in the center of the space.

DX/HL HEATER INSTALLATION CHART				
MODEL NO.	TYPICAL MOUNTING HEIGHT (FT)	DISTANCE BETWEEN HEATERS (FT) DIM "A"	DISTANCE BETWEEN HEATER ROWS DIM "B"	MAXIMUM DISTANCE BETWEEN HEATER AND WALL (FT) DIM "C"
DX (20, 30, 40)-50 (N, P)	10-15	10-25	12-60	16
DX (20, 30, 40)-60 (N, P)	11-16	11-30	14-65	17
DX (20, 30, 40)-75 (N, P)	12-18	12-35	15-70	20
DX (30, 40, 50)-100 (N, P)	13-20	13-40	16-85	20
DX (40, 50, 60)-125 (N, P)	15-25	14-43	17-90	25
DX (40, 50, 60)-150 (N, P)	16-30	15-45	18-100	25
DX (40, 50, 60)-175 (N, P)	17-35	16-50	19-110	30
DX (50, 60, 70, 80)-200 (N, P)	18-40	17-55	20-120	30
HL (20, 30, 40)-75 (N, P)	11-18	11-30	14-70	17
HL (30, 40, 50)-100 (N, P)	12-20	12-40	15-80	20
HL (40, 50, 60)-150 (N, P)	15-30	13-45	17-100	20
HL (60, 70)-200 (N, P)	17-40	15-55	18-120	30

NOTE: This chart is provided as a guideline. Actual conditions may dictate variation from this data.

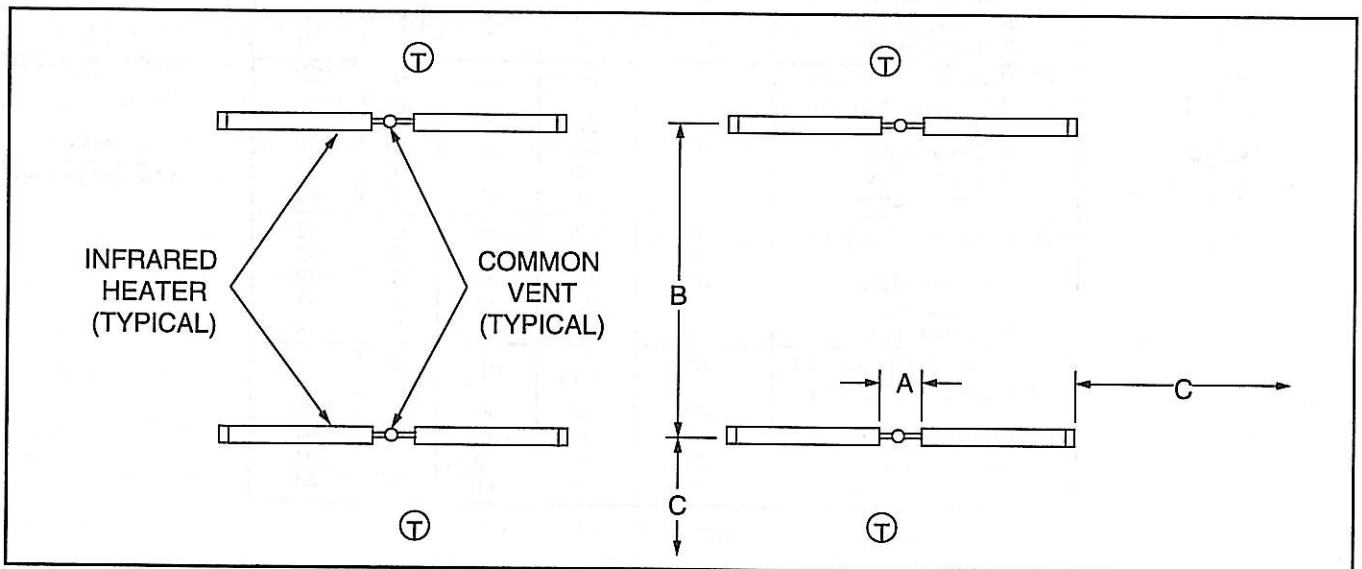

(T) Thermostat

Figure 2-1

TYPICAL BUILDING LAYOUT

When positioning heaters, keep in mind the clearances to combustible materials, lights, sprinkler heads, overhead doors, storage areas with stacked materials, gas and electrical lines, parked vehicles, cranes and any other possible obstructions or hazards. Refer to the Warnings, Cautions and the Clearance-To-Combustibles Chart in the Safety Information Section and on the heater to verify that a safe installation condition exists.

The following guidelines must also be met to ensure a good installation and proper heater performance:

- DX/HL 200 models normally **must not** be mounted lower than 17 ft above the finished floor. Consult Detroit Radiant if you have a special case requiring a lower mounting height.
- A maximum of two 90° elbows or one 180° elbow can be installed on DX/HL model heaters. The gas input of the heaters, as stated on the rating label, will determine the minimum length of radiant pipe from the control box to the first elbow. (See Optional 90° and 180° Elbows Section.)

NOTE: Flue vent requirements do not change when elbows are installed.

- **Do not** exceed the maximum vent length of 20 ft for exhausting the heater. Consult Flue Venting, Section 2.6.

- Do not combine the exhaust vents of two heaters into a straight-through tee. A Part No. Y or staggered-tee arrangement **must be** used. Heaters sharing the same vent must share the same thermostat. Common vents must have a 6 in. diameter (see Figure 2-1).
- Noncontaminated air for combustion **must** be ducted to the heater if chlorinated or fluorinated contaminants are present in the area where the heater is installed. Consult Combustion Air Requirements section on page 15.
- **Do not** exceed the maximum air intake duct length of 20 ft. Consult Air Intake Duct Chart on page 15.
- Do not draw fresh air to the heater from an attic space. There is no guarantee that adequate air will be supplied.
- All unvented heaters **must** use a vent with flapper, Part No. WVE-GALV.

Once all of the safety precautions and design criteria are met, the actual installation of the heater may begin.

2.2 Prechecks

1. Verify that all parts have been received by checking them against the packing list. If anything is missing, notify the Re-Verber-Ray representative or Detroit Radiant Products.
2. Check the AGA rating label on the heater to verify the model number, the gas to be used and that the clearances to combustibles will be met.
3. Make sure the finished installation will conform to the design requirements listed in the Clearance-To-Combustibles Chart and the figure shown on page 3, and Figure 2-1.
4. While heater is still on the ground, connect a 120 V line to heater, and check glo-bar operation.

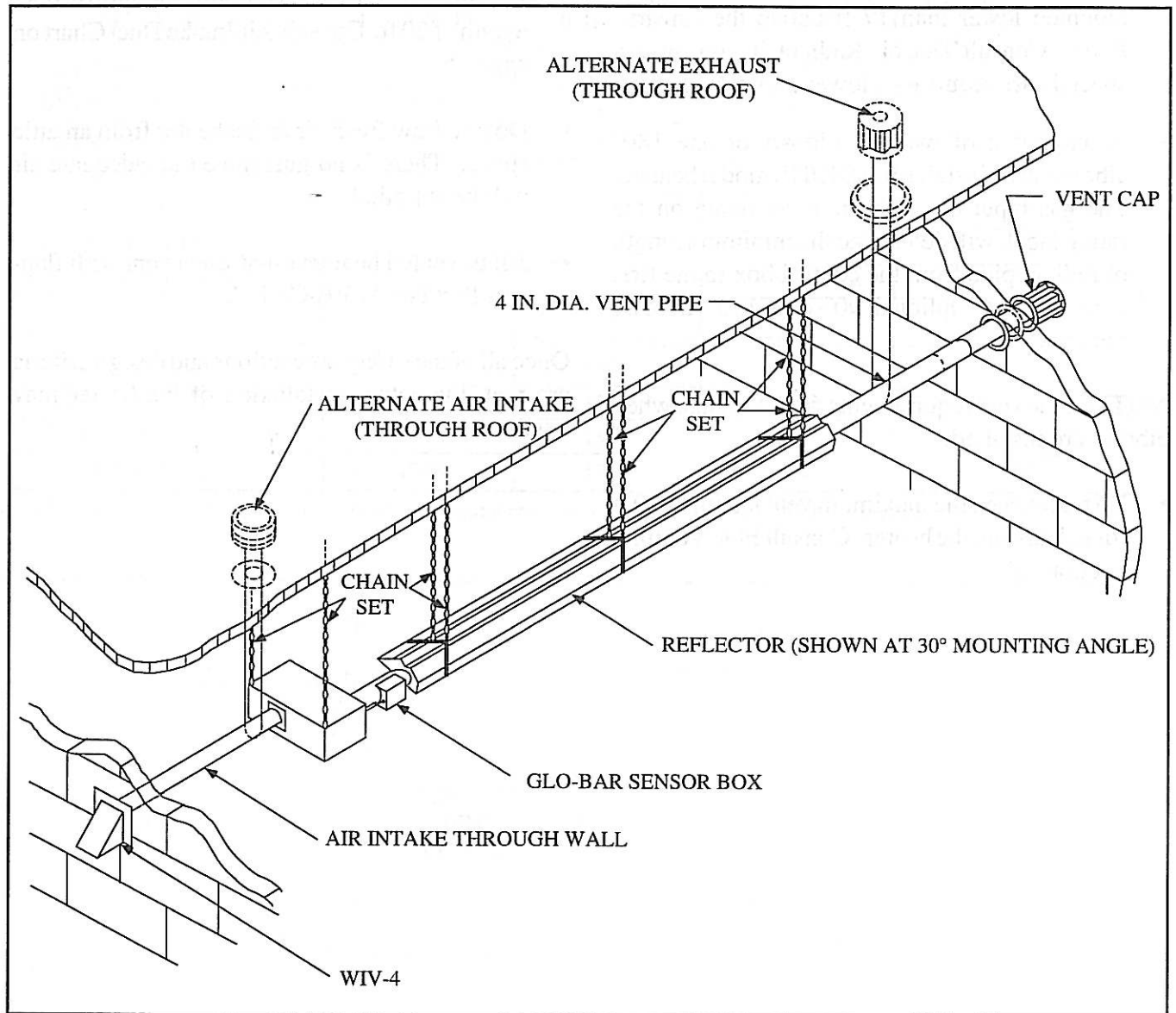
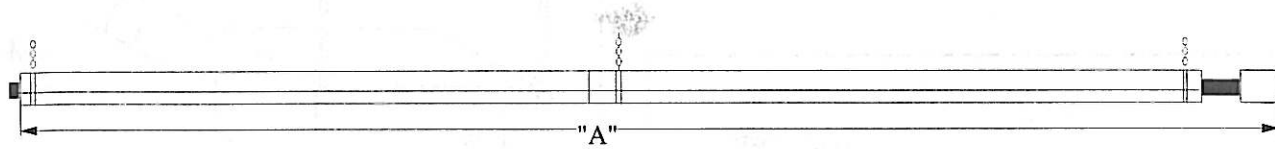
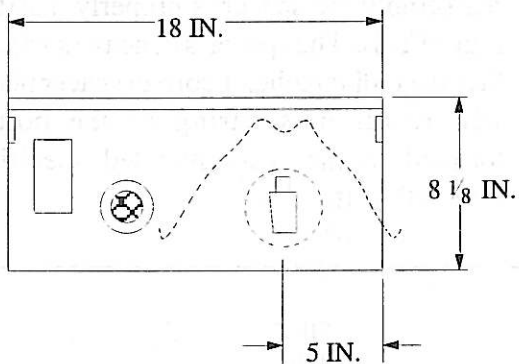

Figure 2-2

TYPICAL INSTALLATION DRAWING



MODEL NO.	DIM. "A"
DX/HL 20	259"
DX/HL 30	375"
DX/HL 40	491"
DX/HL 50	607"
DX/HL 60	723"
DX/HL 70	839"
DX/HL 80	955"



END VIEW

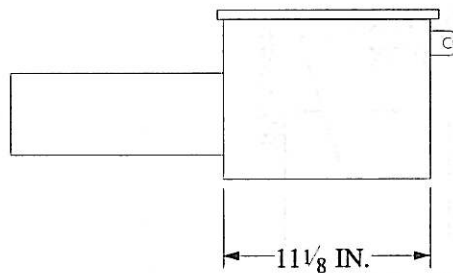

ENLARGED SIDE VIEW

Figure 2-3

DIMENSIONS FOR DX/HL MODELS

2.3 Heater Mounting

1. Each heater comes equipped with the necessary hangers (Figure 2-4) for hanging.

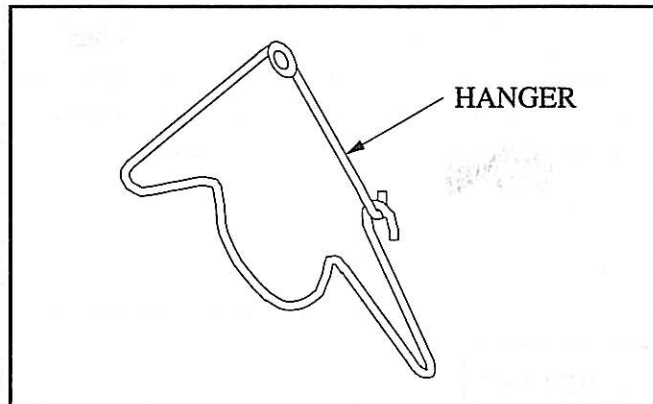

Figure 2-4

2. Use of number 1 double-loop chain is recommended for heater hanging (accessory No. DTH-CS). See Figure 2-5.

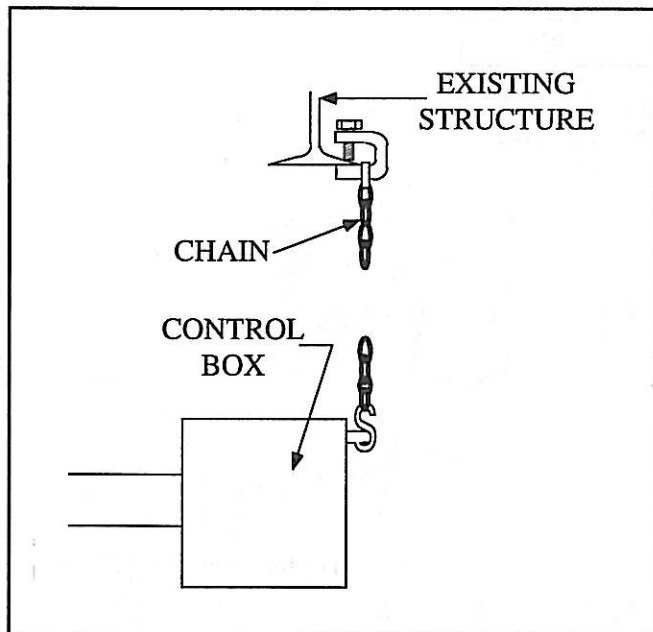

Figure 2-5

NOTE: If windy conditions exist in the space around the heater, it may be necessary to rigidly mount the heater to prevent swaying. It is recommended that threaded rod be used for the two hanging points at the burner control box (see Figure 2-6). The remaining hanging points should use chains to allow for heater expansion.

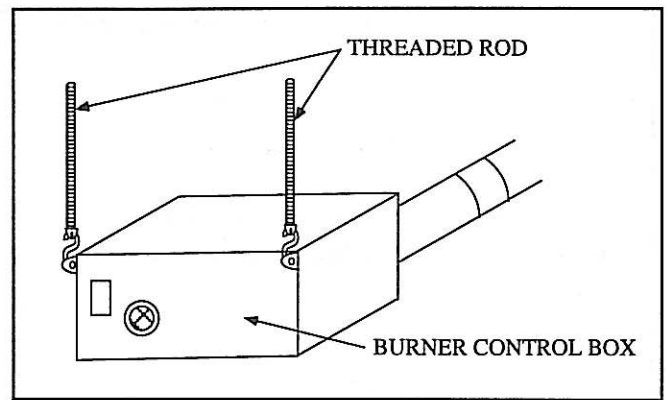

Figure 2-6

3. Mount hangers on approximately 10-ft centers. Slide tubes through hangers with weld seam downward (see Figure 2-7) and fasten with tube clamps (see Figure 2-8). Center clamps on seams.

IMPORTANT: DX/HL 175,000 and 200,000 BTUH models must be installed with a stainless steel tube clamp at the second joint of the exchanger between the first and second radiant tubes.

NOTE: The tube clamps provided with the heater are pre-assembled at the factory. If a clamp is dismantled, it is important that upon reassembly the spacer is properly inserted (see Figure 2-8). The spacer's concave surface **must** face the radiant tube. Incorrect spacer placement will result in shearing of the bolt when torqued to the recommended specifications (50 – 70 lb-ft).

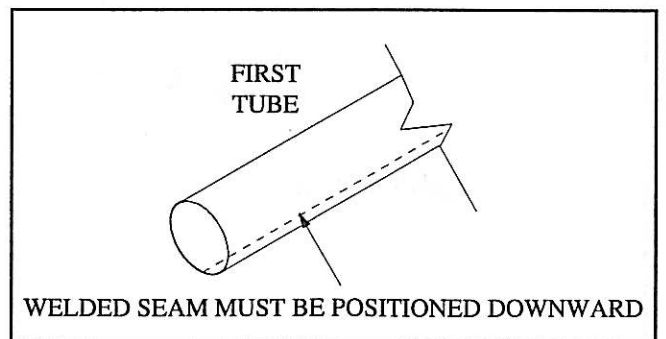

Figure 2-7

IMPORTANT: Radiant tubes with baffles must be installed last (furthest from the burner). See Figure 2-9. All baffles must be in the vertical position.

4. Mount heaters in conformance with approval standards referenced in the Foreword.

5. Install chains perpendicular to the heater.

6. Install heater so that it is independently supported and must not rely on the gas or electrical line for any of its support.

7. Mount heater so that burner sight glass is visible from the floor.

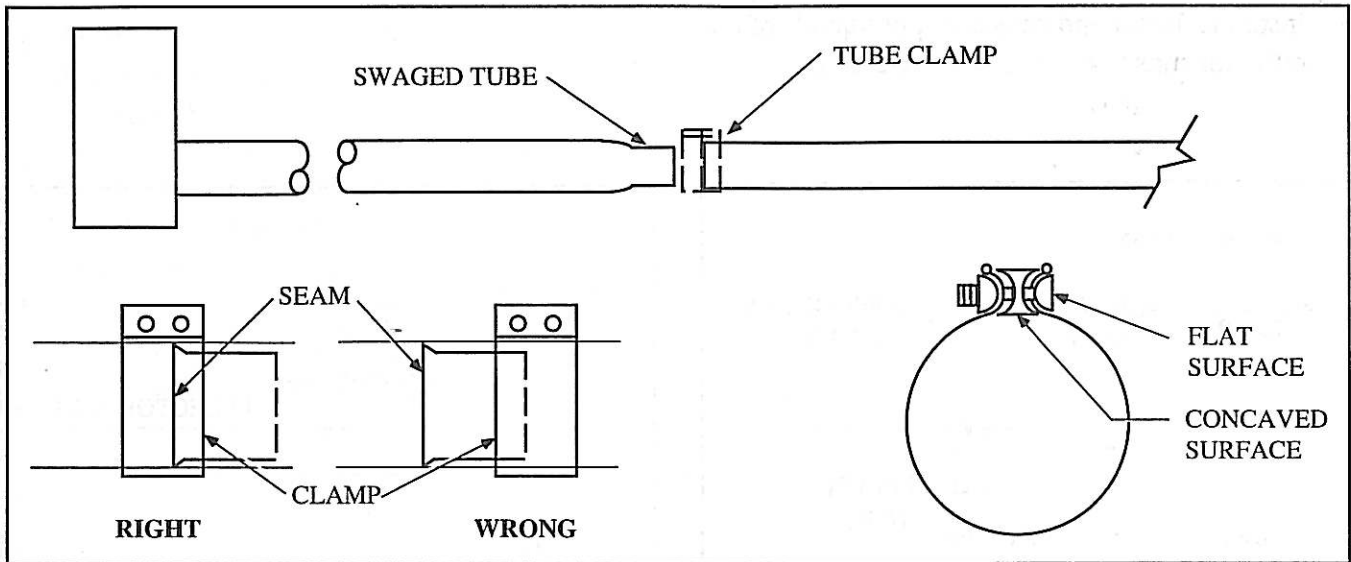

Figure 2-8

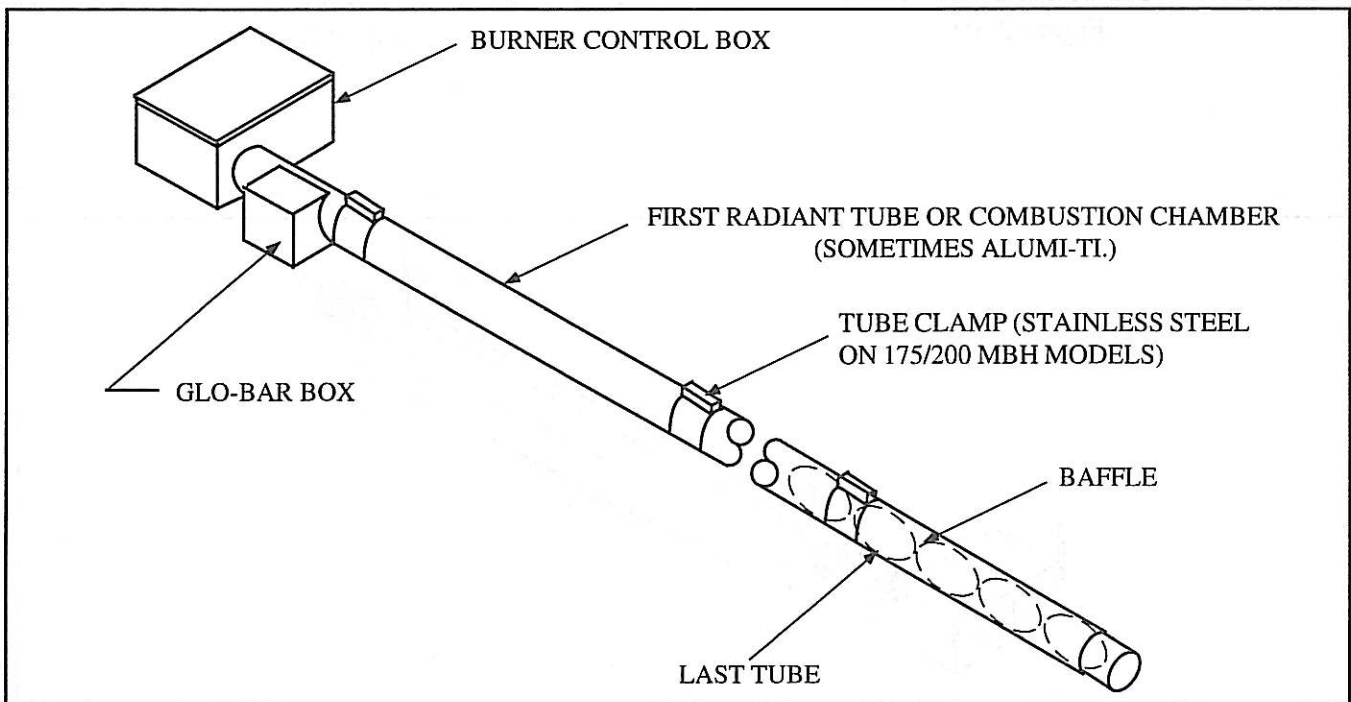

Figure 2-9

2.4 Reflector Assembly

1. Install reflector center supports RCS as shown in Figure 2-10.
2. Slide reflector through wire hangers and adjust the reflector positioning spring in the V-groove on top of the reflector as shown in Figure 2-10. Overlap reflectors 4 in. for support (see Figure 2-10).
3. Install reflector end caps at exposed ends of the reflector runs with clips (Figure 2-11).

Optional Side Shield Installation

1. Install an additional 2 reflector center supports (RCS) 4 ft on each side of the standard RCS.
2. Install the side shield by hooking the edge holes onto the RCSs (Figure 2-12).

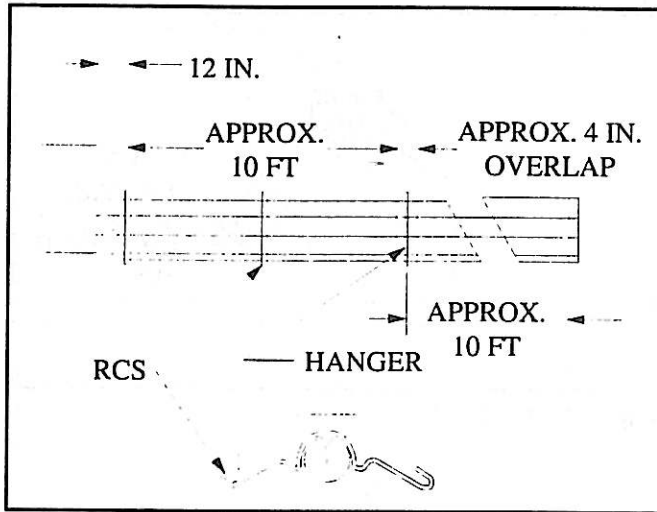

Figure 2-10

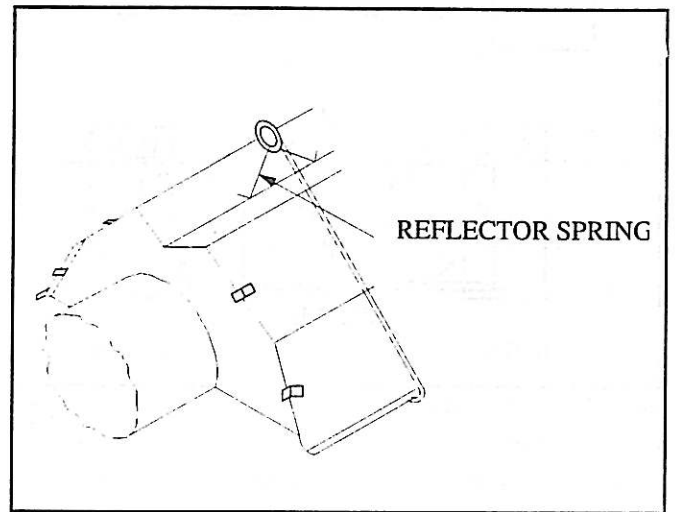

Figure 2-11

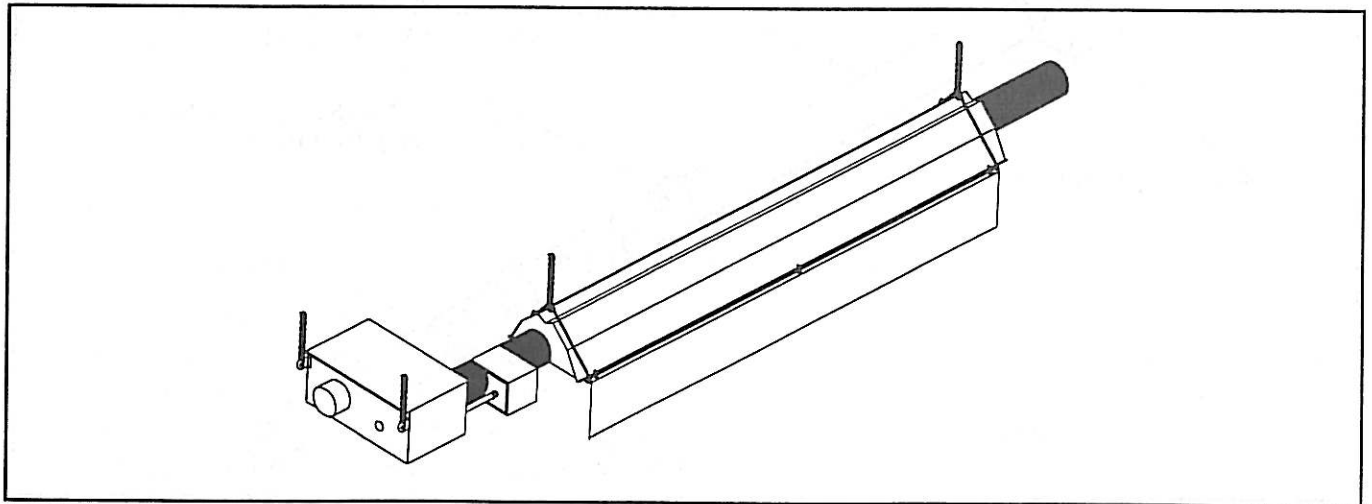

Figure 2-12

2.5 Optional "L" or "U" Configuration

A maximum of two 90° elbows (Figure 2-13) (DRP Accessory #E6) or one 180° U (Figure 2-14) (DRP Accessory #TF1B) may be installed in the exchanger to alter the standard configuration of the heater.

See the Chart and figures below for the minimum distance required between the burner control box and an elbow or "U".

MODEL NO.	MINIMUM DISTANCE FROM THE BURNER TO AN ELBOW OR U FITTING (FT)
DX/HL (20,30,40)-50(N,P) DX/HL (20,30,40)-60(N,P) DX/HL (20,30,40)-75(N,P)	10
DX/HL (30,40,50)-100(N,P) DX/HL (40,50,60)-125(N,P) DX/HL (40,50,60)-150(N,P)	20
DX/HL (50,60,70)-175(N,P) DX/HL (50,60,70,80)-200(N,P)	25

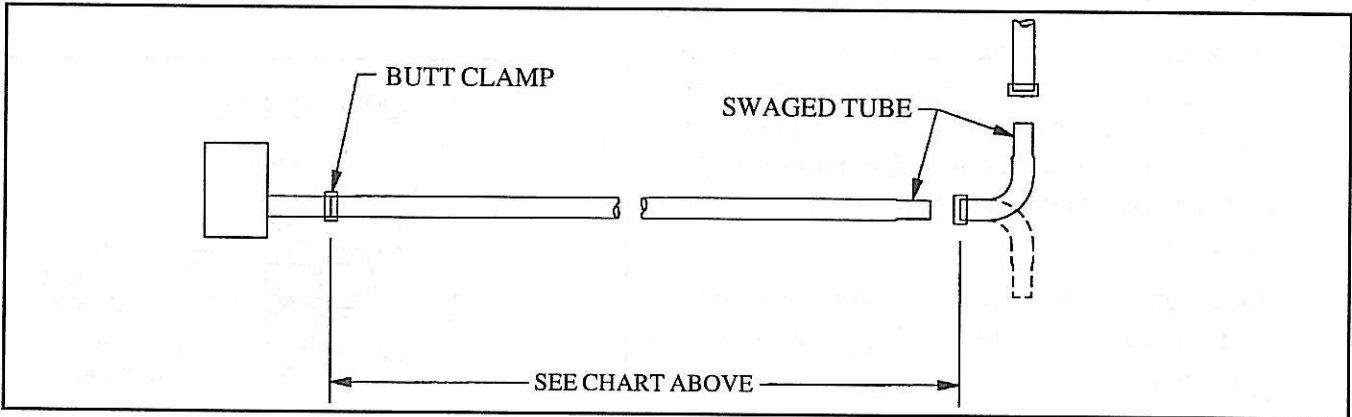

Figure 2-13

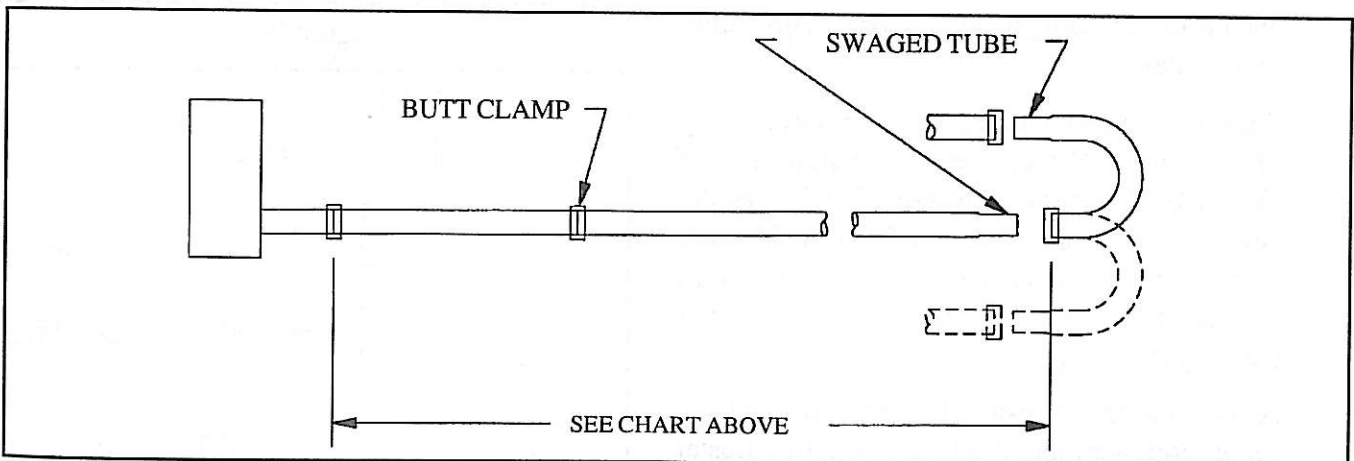

Figure 2-14

2.6 Flue Venting

The following guidelines must be observed to ensure proper system performance and safety:

- Check all applicable codes prior to installing flue stacks. Local codes may vary. In the absence of local codes see the National Fuel Code ANSI Z223.1 (NFPA 54) (latest edition).
- The heater is designed to operate with a 4-in. diameter exhaust stack.
- Single-wall galvanized flue pipe or Dura/Connect single wall, flexible connectors must be used. The portion of the flue pipe which goes through combustible material in the building wall or roof must pass through a type "B" vent to maintain clearances (see Figures 2-15 and 2-16).
- Maximum vent length for all models is 20 feet.
- The venting system shall terminate at least 3 ft (0.9 m) above any forced air inlet located within 10 ft (3.1 m).
- The venting system shall terminate at least 4 ft (1.2 m) below, 4 ft (1.2 m) horizontally from, 1 ft (30 cm) above any door, window, or gravity air inlet into any building. The bottom of the vent terminal shall be located at least 12 in. (30 cm) above grade.
- Uninsulated single-wall metal pipe shall not be used in cold climates for venting gas utilization equipment.
- The vent terminal of a horizontal venting system must be installed to prevent blockage by snow and protect building materials from degradation by flue gases.
- Stacks may exit the building either horizontally or vertically. Vertical venting exiting the roof should be 2 ft above the roof. For horizontal venting, the flue should be 2 in. from the sidewall. Care should be exercised to ensure that vent opening is beyond any combustible overhang (see Figure 2-15).
- A common flue of 6-in. diameter must be used for double-venting of units. One thermostat must control both units. When common vent-

ing is used, flues should be connected so that the by-products of one heater cannot flow into the adjoining flue of the other heater. A dual-exhaust assembly is available from Detroit Radiant, Part No. Y or RT (see Figures 2-18 through 2-20). A Field Controls SK-6 vent cap must be used for sidewall common venting of DX/HL 200 models.

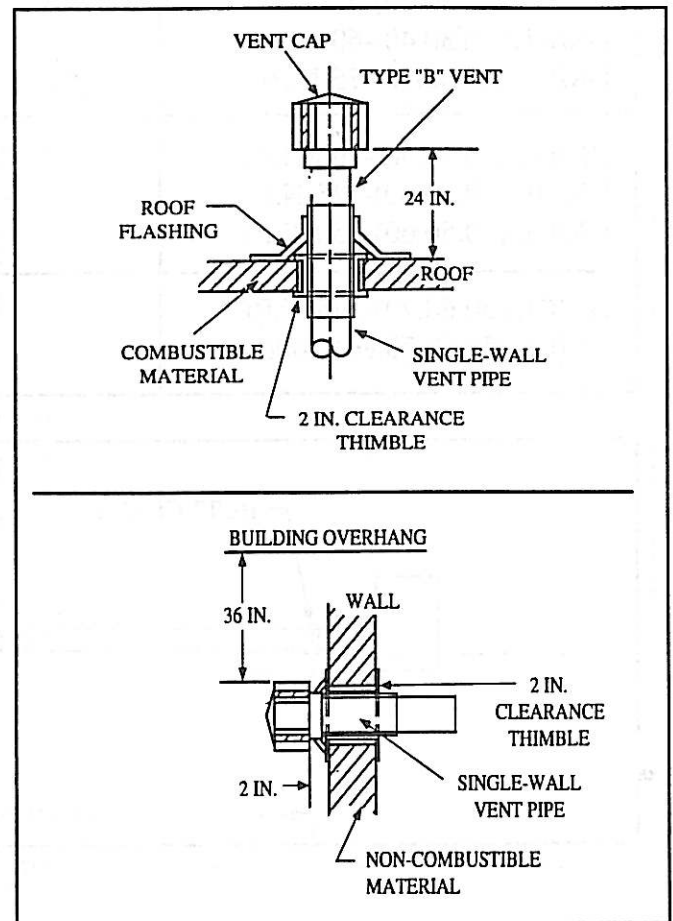

Figure 2-15

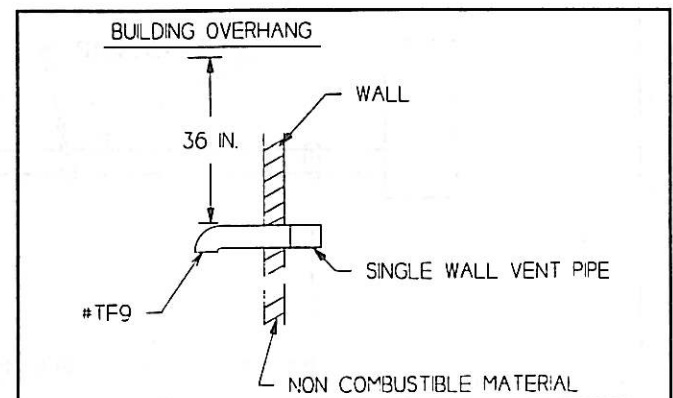

Figure 2-16

IMPORTANT

DX/HL MODELS	APPROVED VENT PACKAGES
50,000 thru 175,000 BTUH	SK-4, SK-6 4 DSK TF-9
200,000 BTUH	SK-4, SK-6 ONLY

-4VC & 6VC Breidert Vent Caps are **not** approved for use with DX/HL models.

- Do not use more than two 90° elbows in the exhaust vent (all models).
- All vent pipes must be sealed with high temperature sealant and 3 No. 8 sheet metal screws to prevent leakage of flue gas into building.
- Horizontal flues should be pitched down toward outlet, 1/4 in. per ft of the vent length, to prevent rain from entering the heater (see Figure 2-17). Do not pitch heater.

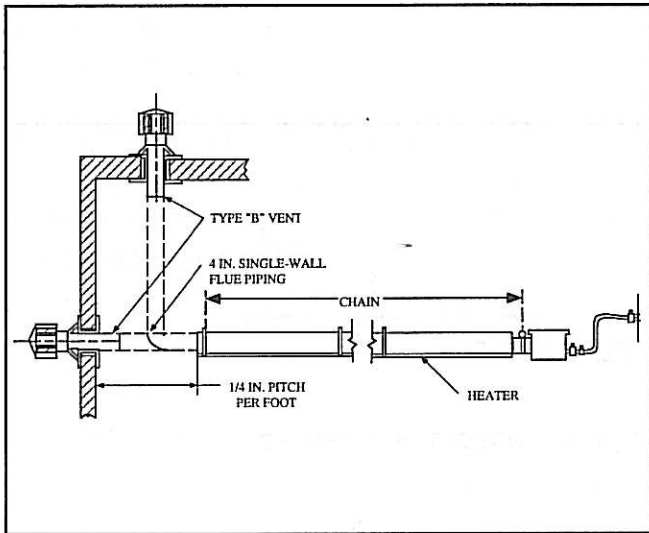

Figure 2-17

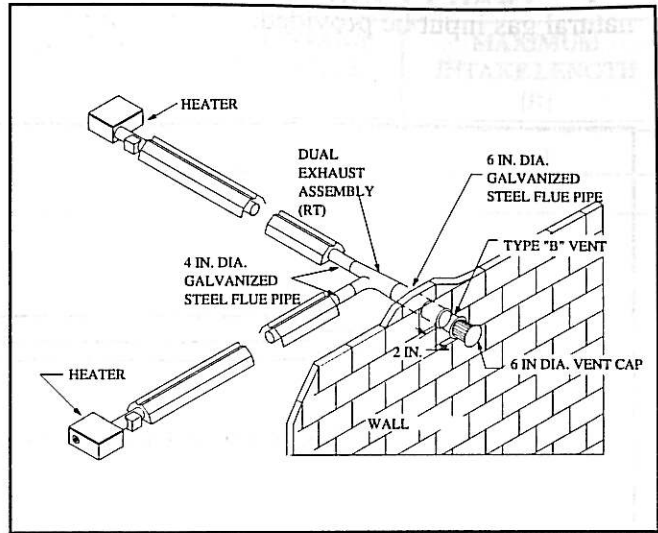

Figure 2-19

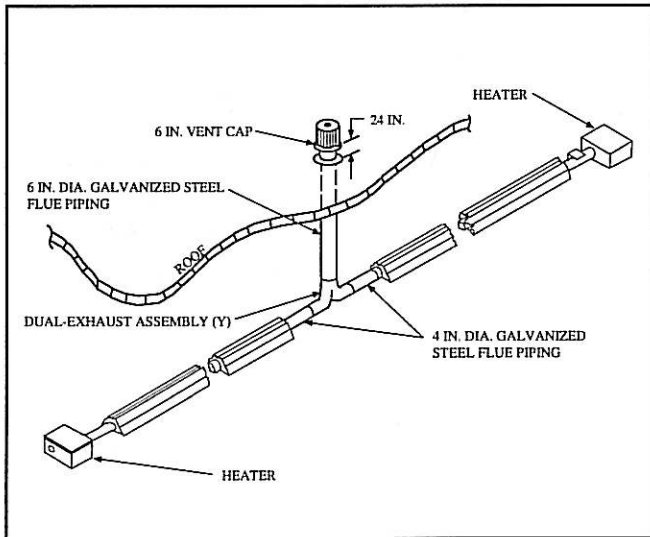

Figure 2-18

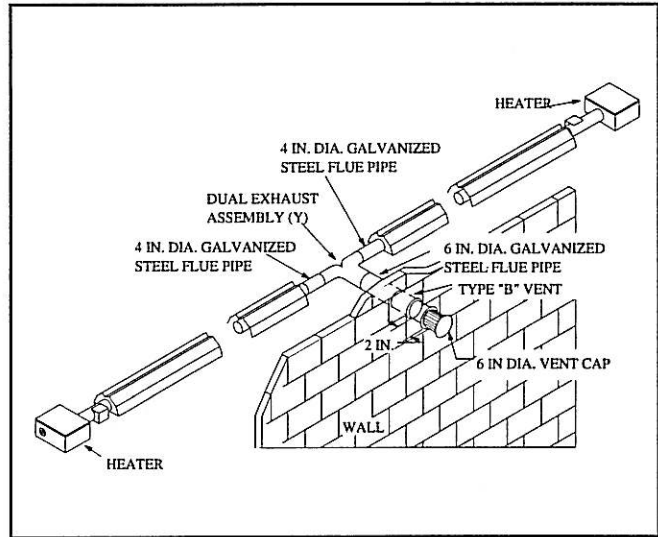

Figure 2-20

DUAL-EXHAUST ASSEMBLY
(THROUGH ROOF)

DUAL-EXHAUST ASSEMBLY
(THROUGH WALL)

2.7 Installation for Unvented Operation (Optional)

The model DX/HL units are approved for unvented operation when equipped with a factory-supplied end cap/diffuser, Part No. WVE-GALV (see Figure 2-21). This allows the products of combustion to be discharged from the units into the space being heated.

Ventilation of the space is required to dilute those products of combustion sufficiently. For proper ventilation, it is recommended that a positive air displacement of at least 3.8 cfm per 1000 Btuh of natural gas input be provided.

If propane is used, a positive air displacement of at least 4.5 cfm per 1000 Btuh of gas input is recommended. This air displacement may be accomplished by either gravity or mechanical means. Provisions must be made for a sufficiently large fresh-air intake area and exhaust-air outlet area, to accomplish the displacement. Local codes may require that the mechanical exhaust system be interlocked with the electrical supply line to the heaters, enabling both to function simultaneously.

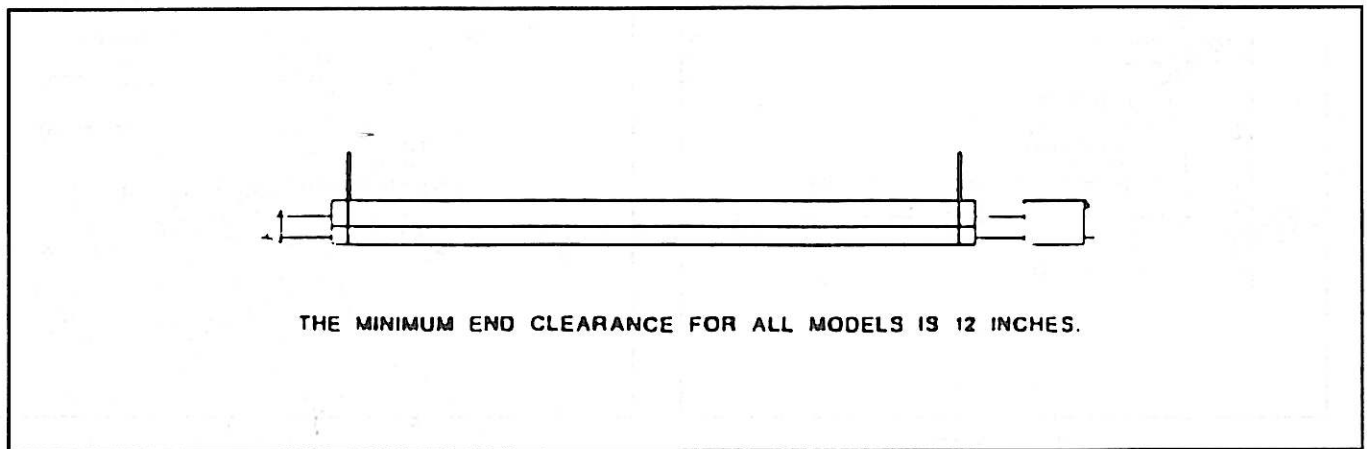

Figure 2-21

2.8 Combustion Air Requirements

Combustion air intake has a factory-preset air orifice. If indoor combustion air is to be supplied for a tightly closed room, one square inch of free air opening should be provided for each 5000 Btuh of heater input.

Noncontaminated air for combustion **must** be ducted to the heater if chlorinated or fluorinated contaminants are present in the area where the heater is installed, or if the building has a negative pressure. Typical sources of these contaminants are refrigerants, solvents, adhesives, degreasers, paint removers, paints, lubricants, pesticides, etc.

Outside combustion air may be provided by an accessory 4-in. air duct, and directly attached over the air orifice (see Figure 2-22). A WIV-4 wall inlet vent must be used with horizontal outside air intake ducts.

The maximum number of 90° elbows allowed is two.

The air intake terminal must be installed to prevent blockage by snow.

NOTE: Use insulated duct or PVC pipe to prevent condensation on outer surface. Keep intake opening at least 3 ft from any exhaust vent openings. For limitations of length and size, see the Air Intake Duct Chart.

AIR INTAKE DUCT CHART		
MODEL	AIR INTAKE DUCT SIZE [in.]	MAXIMUM INTAKE LENGTH [ft]
ALL MODELS	4	20
	5	30

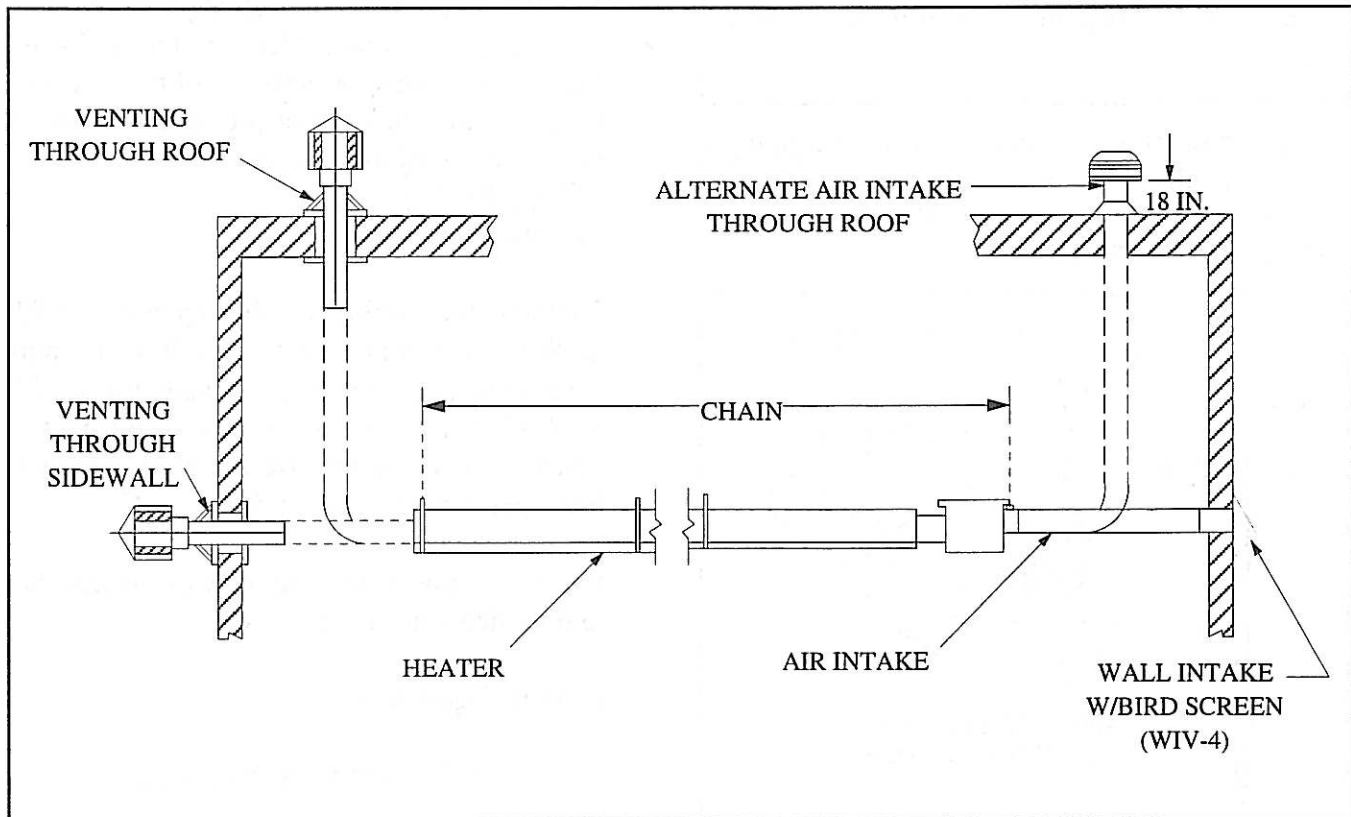

Figure 2-22

2.9 Gas Supply

CAUTION

CORRECT INLET PRESSURES ARE VITAL FOR EFFICIENT OPERATION OF HEATERS. REFER TO AGA RATING PLATE AND, IF NECESSARY, CONSULT GAS COMPANY.

If all or a portion of the gas supply line consists of used pipe, it must be cleaned and then inspected to determine its equivalency to new pipe. Test all main supply lines according to local codes. **(Isolate heater gas valve and supplied gas cock during test.)**

Excessive torque on manifold may misalign orifice. Always use two wrenches when tightening mating pipe connections.



WARNING

Never use a match or any other flame to test for gas leaks. Use soap-and-water solution to check for leaks.

If any portion of the gas supply line is located in an area that could cause an abnormal amount of condensate to occur in the pipe, a sediment trap should be installed (see Figure 2-23).

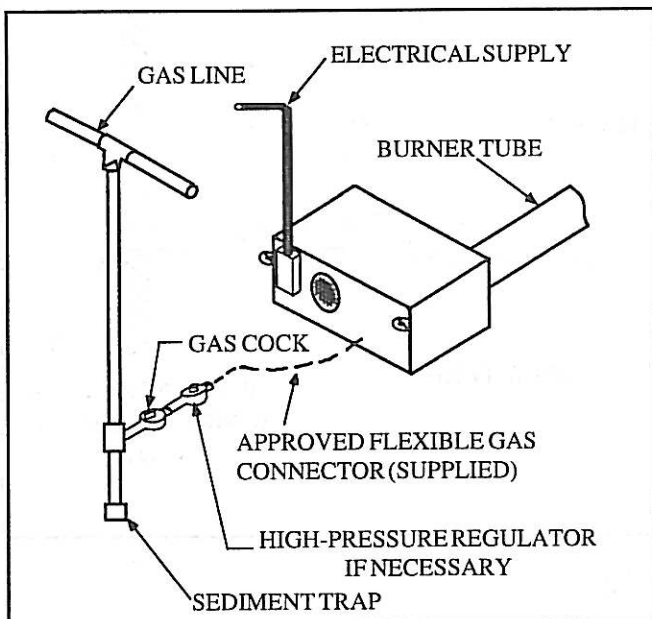

Figure 2-23

NOTE: For high-pressure gas above 14 in. W.C. (Water Column), a high-pressure regulator and gas cock must be used. If compressed air is used to detect leaks in the gas supply line, disconnect and cap at shutoff cock to avoid damage to regulator and gas valve.

A typical gas supply line connection is illustrated in Figure 2-24. The method shown will decrease the possibility of any loose scale or dirt in the supply line entering the heater's control system and causing a malfunction. Provide a 1/8 in. (3.2 mm) NPT, plugged tapping accessible for test gauge connection immediately upstream of gas connection to heater. The gas supply line must be of sufficient size to provide the required capacity and inlet pressure to the heater (consult gas company) as follows:

NOTE: Manifold pressure should be checked at the tap on the gas valve. Readings will be above atmospheric pressure

- Natural Gas

To obtain the required manifold pressure of 3.5 in. W.C., a minimum inlet pressure of 5.0 in. W.C. is necessary for purposes of input adjustment. A maximum inlet pressure of 14.0 in. W.C. is allowed for all units.

- Liquefied Petroleum Gas

To obtain the required manifold pressure of 5.0 in. W.C., a minimum of 11.0 in. W.C. for purposes of input adjustment to a maximum of 14.0 in. W.C. must be provided ahead of the control system on each heater. **Do not** exceed a manifold operating pressure of 5.0 in. W.C.

Use only a pipe-joint compound that is resistant to liquefied petroleum gases.

- Pressure Equivalents

1 in. W.C. equals 0.58 oz/sq. in.

- Allowance for Expansion

Allowances must be made for the system to expand. The supplied stainless-steel, flexible gas connector is recommended. If, however, local codes require rigid piping to the heater, a swing joint can be used.

- Gas Line Connection

- a. The gas outlet shall be in the same room as the appliance and the connector must not be concealed within or run through any wall, floor or partition.

- b. The connector shall be of adequate length.

- c. The final assembly shall be tested for leaks. **CAUTION:** Matches, candles, open flame or other sources of ignition shall not be used for this purpose. Leak test solutions may cause corrosion – water rinse after test.

- d. Contact with foreign objects or substances shall be avoided.

- e. The connector shall not be kinked, twisted or torqued.

- f. Connectors are not designed for movement after installation. Bending, flexing or vibration must be avoided.

- g. Connectors are for use only on piping systems having fuel gas pressures not in excess of 1/2 pound per square inch.

CAUTION

CONNECTOR NUTS MUST NOT BE CONNECTED DIRECTLY TO PIPE THREADS. THIS CONNECTOR MUST BE INSTALLED WITH ADAPTORS PROVIDED. DO NOT REUSE.

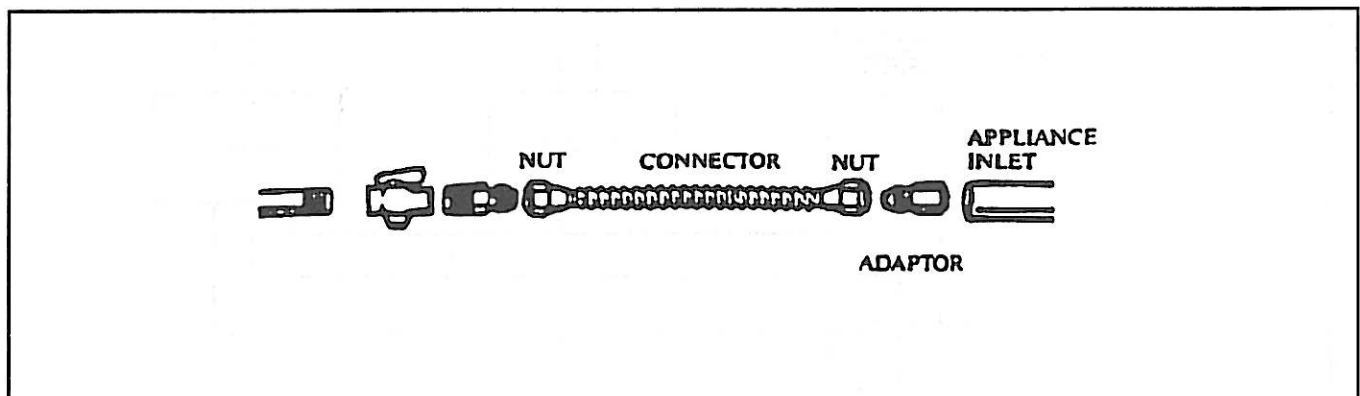

Figure 2-24

2.10 Electrical Requirements

1. Heaters operate on 120 volts, 60 Hz, single phase. The maximum amperage requirement (starting current) is 4.8 amps per heater. The running current is 1.1 amps.
2. Heater must be grounded in accordance with the National Electrical Code ANSI/NFPA 70 (latest edition).
3. Wiring must not be run above or below the heater, nor exposed to the radiant output.
4. Observe proper electrical polarity.

DX Models

It is recommended that the thermostat be installed on the hot side of a fused supply line and have a sufficient ampere rating for the heater(s) it controls.

HL Models

HL Models require a 24V two-stage thermostat to operate. Each heater has a plug-in terminal for the thermostat wiring and supplies its own control voltage. See Figure 3-4 for thermostat connections. If two or more HL models are to be controlled by a single thermostat, an optional relay must be installed and the heaters wired as shown in Figure 2-25.

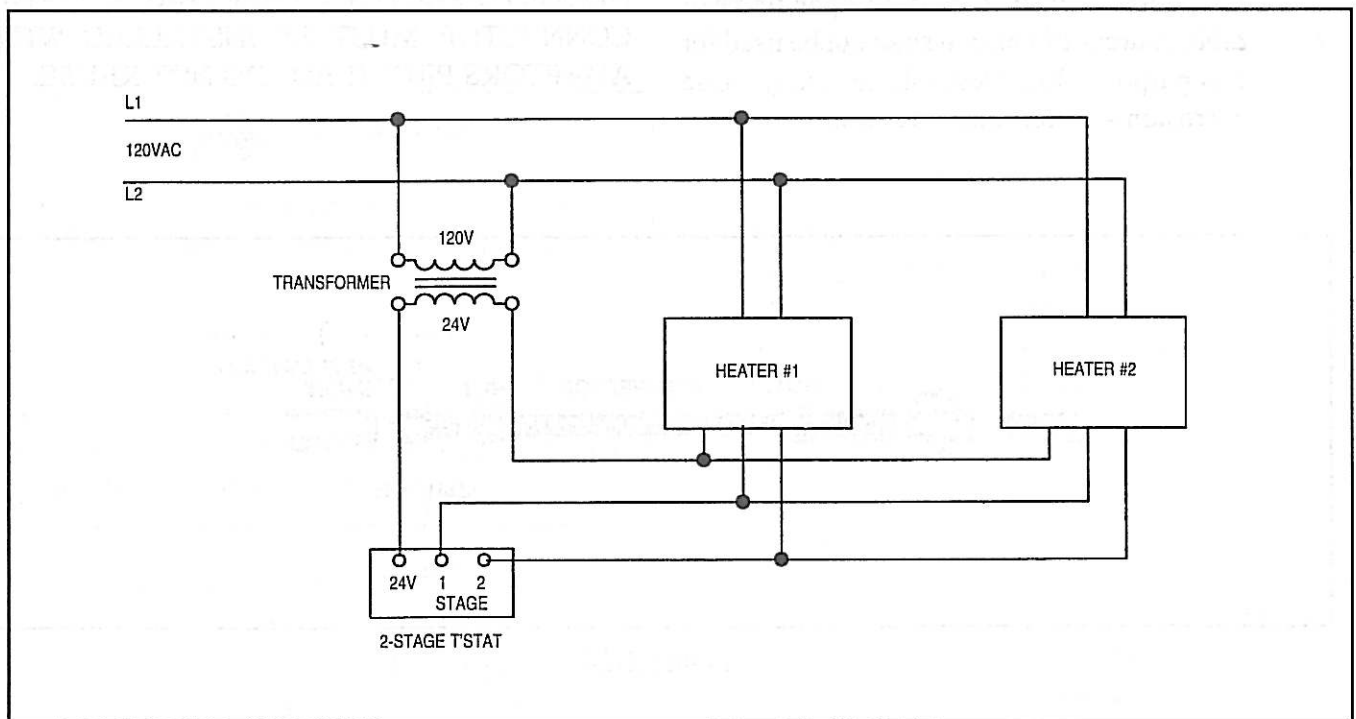

Figure 2-25

2.11 Lighting Instructions

1. Purge main gas supply line at start-up.
2. Rotate heater's manual gas valve knob to the "ON" position.
3. Close electrical circuit.
4. If heater fails to light, turn off gas and wait five minutes before repeating the above procedure.

2.12 Shutdown Instructions

1. Open electrical circuit.
2. Rotate heater's manual gas valve knob to the "OFF" position.

3.2 HL MODELS

LO FIRE

• Starting Circuit (Figures 3-3 and 3-4)

When the first stage of a two-stage thermostat calls for heat, the fan relay in the circuit control starts the fan. When the fan creates a sufficient positive pressure in the burner control box, the normally open pressure switch closes, initiating the ignitor sequence. The glo-bar is powered and after 45 seconds the main valve opens. Power to the glo-bar is shut off during the last three seconds of the ignition trial.

• Running Circuit

When power is removed from the glo-bar, the glo-bar is utilized as a flame probe. As long as a flame

is present, the valve is held open. If the flame is lost, the control acts to close the valve within one second, and a new trial sequence identical to that at start-up is initiated. If proof of flame is not established within 8.5 seconds, the unit will lock out. If lockout occurs, the control can be reset by briefly interrupting the power source.

HI FIRE

The second stage can be energized at any time during the operation causing the heater to operate in the HI fire mode. This is accomplished by a solenoid which pushes down on the regulator increasing the manifold pressure and therefore the BTUH input of the heater.

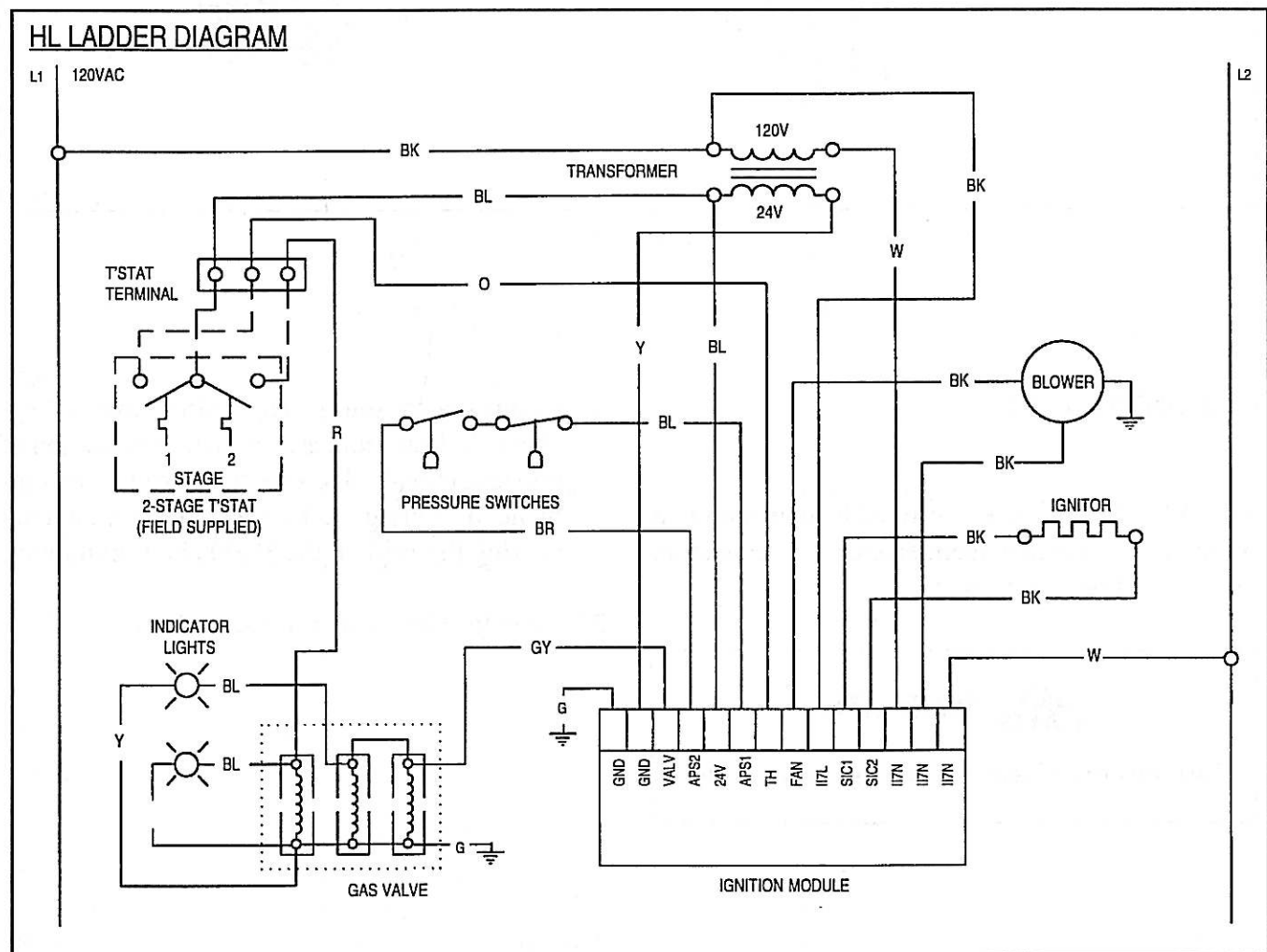

Figure 3-3

4.1 Troubleshooting Chart

GENERAL TROUBLESHOOTING CHART		
SYMPTOM	POSSIBLE CAUSE	CORRECTIVE ACTION
Thermostat closed but nothing happens.	<ol style="list-style-type: none"> 1. Blown fuse. 2. Defective thermostat. 3. Loose or disconnected wire. 4. Defective fan. 	<ol style="list-style-type: none"> 1. Replace. 2. Replace. 3. Repair as required. 4. Lubricate, repair or replace.
Thermostat closed. Fan operates. No glo-bar energization.	<ol style="list-style-type: none"> 1. Loose or disconnected wire. 2. Plugged or restricted exhaust vent. 3. Plugged pressure switch lines. 4. Defective pressure switches. 5. Defective glo-bar. 6. Defective circuit control. 7. Box lid or gasket not in place. 	<ol style="list-style-type: none"> 1. Repair as required. 2. Remove foreign matter. 3. Clean as necessary. 4. Replace only. Do not adjust. 5. Replace. 6. Replace circuit control. 7. Put in place.
Thermostat closed. Fan and glo-bar operate. After 45 seconds glo-bar shuts off. No reignition.	<ol style="list-style-type: none"> 1. Closed gas supply. 2. Dirty or restricted orifice. 3. Defective valve. Disconnected valve wire. 	<ol style="list-style-type: none"> 1. Open all gas connections. 2. Remove and clean with a soft object. 3. Replace or repair.
Loss of heater efficiency.	<ol style="list-style-type: none"> 1. Low gas pressure. 2. Dirty or restricted orifice. 3. Foreign matter inside burner assembly. 4. Unit cycles on and off. 5. Reflector is sooted and has lost its reflective ability. 6. Reflector not in place. 7. Clogged fan blower. 	<ol style="list-style-type: none"> 1. Provide required gas pressure. 2. Remove and clean with a soft object. 3. Clean as necessary. 4. Check previous symptom. 5. Clean with aluminum cleaner and soft wiping cloth. 6. Put in place. 7. Clean.
Radiant tube leaking burnt gases.	<ol style="list-style-type: none"> 1. Loose tube connections. 2. Holes or cracks in radiant tubes. 	<ol style="list-style-type: none"> 1. Assure that tube is fully inserted into flared end and properly clamped. 2. Replace.
Condensation.	<ol style="list-style-type: none"> 1. Stack length too long. 2. Light gauge flue stack used. 	<ol style="list-style-type: none"> 1. Shorten stack. 2. Minimum of 26 gauge vent pipe is required.
Tube bowing.	<ol style="list-style-type: none"> 1. Insufficient combustion air. 2. Overfired. 	<ol style="list-style-type: none"> 1. Provide 2 sq. in. of free air per 5000 Btuh of input. 2. Check gas pressure and orifice size.
Tube corroding.	<ol style="list-style-type: none"> 1. Contaminated combustion air. 	<ol style="list-style-type: none"> 1. Provide fresh air inlet duct.
Visual inspection of burner operation not possible.	<ol style="list-style-type: none"> 1. Dirty or sooted sight glass. 2. Unit mounted upside down. 	<ol style="list-style-type: none"> 1. Remove, clean or replace. 2. Mount correctly.
Stack sooting.	<ol style="list-style-type: none"> 1. Insufficient combustion air. 2. Improper gas. 	<ol style="list-style-type: none"> 1. Provide 1 sq. in. of free air for every 5000 Btuh of input. 2. Correct with proper gas input.
Thermostat closed. Fan and glo-bar operate. Ignition occurs. Burner cycles off and will not recycle.	<ol style="list-style-type: none"> 1. No electrical ground. 2. Defective circuit control. 3. Low gas pressure. 4. Circuit control connection. 	<ol style="list-style-type: none"> 1. Connect electrical ground to junction box. 2. Replace. 3. Provide required gas pressure. 4. Repair or replace.
Thermostat closed. Fan and glo-bar operate. Ignition occurs. Burner cycles off. Burner cycles on.	<ol style="list-style-type: none"> 1. Low gas pressure. 2. Baffle improperly positioned. 3. Defective exhaust pressure switch. 4. Restricted flue vent. 	<ol style="list-style-type: none"> 1. Provide required gas pressure. 2. Reposition baffle (see page 9). 3. Replace. 4. Remove foreign matter.

5 PARTS LIST

5.1 Basic Parts List

Part No.	Description
TP 1.	Control Box Cover
TP 2.	Control Box End—DX
TP 3.	#8 x 1/4 in. Sheet Metal Screw
TP 4A.	Control Box
TP 5.	Gasket
TP 7.	1/4-20 x 1/2 in. Machine Screw
TP 7A.	1/4-20 Hex Nut
TP 9.	Conduit Coupling
TP 10.	Conduit 1/2 in. x 4 in.
TP 11.	Glo-Bar Box
TP 12.	Glo-Bar Box Covers
TP 13.	#8 x 1/2 in. Self-Drilling Screw
TP 14.	Sight Glass Gasket
TP 15.	Sight Glass
TP 16.	Sight Glass Washer
TP 17.	1/4-20 x 3/8 in. Thread-Cutting Screw
TP 19B.	Wire Hanger
TP 20C.	Reflector (120 in.)
TP 21B.	Tube Clamp
TP 26A.	10 ft Radiant Tube, Straight
TP 26B.	10 ft Radiant Tube, Straight (AL-TI)
TP 31B.	Control Box Bracket
TP 33B.	Gas Cock
TP 41.	1/4-20 Keps Nut
TP 44B.	1-5/16 in. Inlet Air Orifice w/Screen
TP 44C.	1-1/2 in. Inlet Air Orifice w/Screen
TP 44E.	1-5/8 in. Inlet Air Orifice w/Screen
TP 44H.	1-3/4 in. Inlet Air Orifice w/Screen
TP 44K.	2-1/8 in. Inlet Air Orifice w/Screen
TP 50.	Glo-Bar Ignitor
TP 54.	Burner Box Divider
TP 55A.	Fan Blower
TP 56C.	1/4 in. Atmosphere Tube (Vinyl)
TP 57A.	1/4 in. Pressure Tube

Part No.	Description
TP 59.	#8 Hex Nut/Lock Washer
TP 60 E.	Exhaust Pressure Switch (Tridelta #FS6628-1654)
TP 61B.	Burner Pressure Switch (Tridelta #FS6581-1047)
TP 62.	#8 x 1/2 in. Machine Screw
TP 65B.	99 in. Heat Diffuser (Baffle)
TP 65C.	132 in. Heat Diffuser (Baffle)
TP 66.	2 in. x 4 in. Outlet Box
TP 67.	2 in. x 4 in. Outlet Box Cover
TP 68A.	Strain Relief Bushing
TP 70.	Control Box Cover Gasket
TP 76.	Rubber Grommet
TP 78A.	Mark-17X-117 Circuit Board (DX)
TP 80.	#6-32 x 1 in. Machine Screw
TP 81.	#6-32 Hex Nut
TP 82.	Reflector Center Support
TP 83.	Flexible Gas Connector
TP 101.	1/2 in. Adapter Fitting
TP 104.	1/2 in. x 2 in. Pipe Nipple
TP 105.	Reflector End Cap
TP 106.	Reflector Clip
TP 200.	Burner (50,000 to 100,000 BTUH)
TP 201.	Burner (125,000 to 200,000 BTUH)
TP 202.	16 in. Burner Tube
TP 203.	DX End Panel-Right
TP 204.	Gas Orifice
TP 205.	Glo-Bar Holder
TP 206.	HL End Panel-Left
TP 207.	HL End Panel-Right
TP 208.	"Z" Bracket
TP 209.	36E36A-246 Gas Valve (DX-Natural Gas)
TP 209P.	36E36A-246 Gas Valve (DX-Propane Gas)
TP 210.	36E96-224 2-Stage Gs Valve (HL-Natural Gas)

Part No.	Description
TP 210P.	36E96-224 2-Stage Gas Valve (HL-Propane Gas)
TP 211.	Mark-17X-24 Circuit Board (HL)
TP 212.	3 in. x 1/2 in. Pipe Nipple
TP 213.	T-Stat Plug (HL)
TP 214.	Glo-Bar Harness (HL)
TP 215.	Wiring Harness (DX)
TP 216.	Indicator Light (HL)
TP 217.	Pressure Barb Fitting
TP 218.	Exhaust Pressure Tube (Vinyl)
TP 219.	Glo-Bar Holder Gasket
TP 220.	Stainless Steel Tube Clamp

NOTE: When ordering heater parts, please state the model and serial number of the heater.

5.2 Optional Parts

Item No.	Description
SK-4	Vent Cap (Required For Sidewall Venting)
WVE-GALV	Exhaust Vent w/Flapper (Required on Unvented Models)
WIV-4	Wall Inlet Vent w/Screen
4 DSK	Side Wall Venting Kit
TF 9	Truck Exhaust Terminal for Side Wall Venting
SK-6	Vent Cap (Required for Dual Side Wall Vents)
SSE	Side Shield Extension

